

# SEVENCRAANE

Henan Seven Industry Co.,Ltd

Address: Changyuan, Xinxiang City, Henan province, China.

Email: [info@sevencrane.com](mailto:info@sevencrane.com)

Tel: (00)86-371-55576206

Web: [www.sevencrane.com](http://www.sevencrane.com)

Henan Seven Industry Co.,Ltd

# European Type Electric Hoist



**SEVENCRAANE**

## Company profile

SEVENCRANE (Henan Seven Industry Co., Ltd) offers our customers with reliable, safe and high-performance solutions for industrial cranes, crane components and drives. SEVENCRANE serves a wide range of industries including machinery, metallurgy, power industry, railways, water conservancy, ports, mines, coal, petroleum, chemical industries, etc.

SEVENCRANE stands for first-rate service, cost-effective, high quality. Based on our brand commitment, we provide butler-style services to our customers at all stages, and fully consider the solutions for the purchase, production, transportation, installation and after-sale process of cranes.

Our customers appreciate our reliability and professionalism. Our sales staffs are trained in professional crane knowledge and customers can communicate with them on technical issues directly.

### Values and vision

**SEVENCRANE is committed to the highest efficiency, best results and best service. Choose SEVENCRANE to give you peace of mind and focus on your business.**

**Our core values: First class service—Safety—Efficient—Reliable**

*" Tell sevenscrane your needs and leave the rest to us. "*

### Business area

Spare parts and service	Industrial cranes
SEVENCRANE provides components and maintenance services for all types of cranes to help customers increase productivity and perform crane maintenance or assembly.	SEVENCRANE serves a wide range of industries including machinery, metallurgy, power industry, railways, water conservancy, ports, mines, coal, petroleum, chemical industries, etc. We offer cranes, solutions of crane and material handling solutions to a wide range of customers.
Product: SEVENCRANE can provide: Rail system, Bus bar, Remote control, Wire rope, All kinds of hook block, Wheels, Couplings, Drums, Buffers, End carriage, Pulley, Grab buckets, Crane magnet. We also provide crane system design, crane installation and training for our customers, and have perfect after-sales service.	Product: SEVENCRANE provide customers in various industries: Gantry crane, Bridge crane, Jib crane, Electric hoist, Winch, European type crane.



# Qualification Certificate



IOS certificate occupational and health



ISO certificate environment

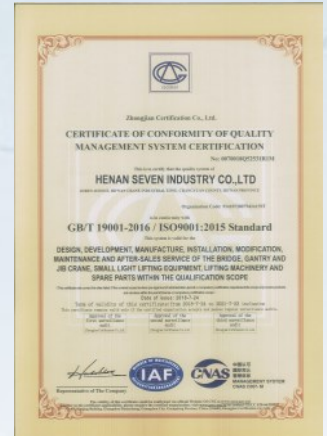

ISO certificate quality



Special equipment manufacturing certificate



China heavy machinery industry association-Membership certificate

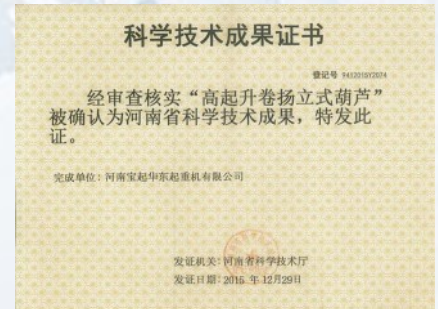

Certificate of scientific and technological achievements



Safety mark certificate for mineral products



Abide by the contract honor enterprise



Safety production license

## European type electric hoist



### Overview

Our European type electric hoists adopt advanced European technology, and the overall technical level has reached the advanced level of similar products at home and abroad. The European-type electric hoist is characterized by compact structure, light weight, small wheel pressure, large space utilization, and high cost performance. At the same time, the larger working range of the European-type electric hoist can increase the utilization rate of the internal area of the plant and reduce the blind spot. Moreover, it adopts modular design, has low maintenance cost, convenient maintenance and complete spare parts service. The appearance and parameter performance design are particularly obvious, and it is the star product of our company.

### Specification

1. Load capacity: 1t~80t
2. Lifting height: 6m/9m/12m/15m/18m
3. Working duty: FEM 2m/ISO M5
4. Lifting speed: 0.8/5 m/min 0.64/4 m/min
5. Traveling speed: 2~20m/min
6. Power supply: 380v/400v/415v/460v/, 50hz/60hz, 3p
7. Protection class: IP55
8. Working temperature: -20°C ~ +40°C

### Advantages

- three-in-one motor, high reliability, small size
- High-efficiency motor with hardened gear reducer for low energy consumption and high torque output
- High-precision automatic adjustment of electromagnetic brake for fast, low noise and reliable
- High-strength, high-flexibility wire rope for greater and safer pulling force
- High-strength nylon rope guide, pulley, self-lubricating to achieve longer wire rope life
- High-strength alloy wheel set for longer wheel life
- Modular design for flexible combination



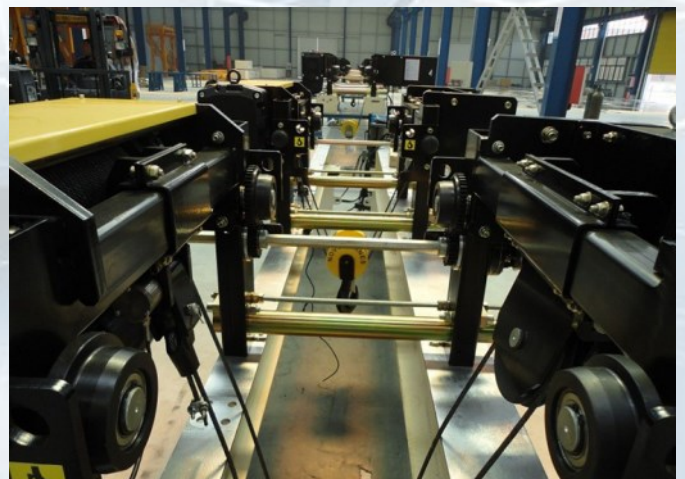

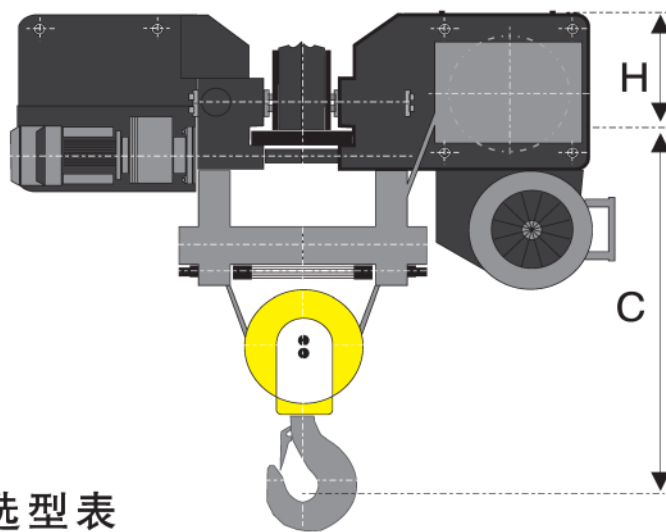

### NWH单梁钢丝绳电动葫芦选型表

Selection table of NWH single girder wire rope hoist

额定载荷 S.W.L (Kg)	工作级别 FEM	工作级别 ISO	起升高度 Lifting height (m)	起升速度 Lifting speed (m/min)	运行速度 Travelling speed (m/min)	H 尺寸 Size H (mm)	C 尺寸 Size C (mm)
1000	4m	M7	6/9/12/18	0.8/5.0	5~20	232	500
1250	3m	M6	6/9/12/18	0.8/5.0	5~20	232	500
1600	3m	M6	6/9/12/18	0.8/5.0	5~20	232	500
1600	2m	M5	6/9/12/18	1.6/10	5~20	232	500
2000	2m	M5	6/9/12/18	0.8/5.0	5~20	232	500
2000	3m	M6	6/9/12/18	1.3/8.0	5~20	232	500
2500	3m	M6	6/9/12/18	0.8/5.0	5~20	232	500
2500	3m	M6	6/9/12/18	1.0/6.3	5~20	232	500
2500	2m	M5	6/9/12/18	1.3/8.0	5~20	232	500
3200	2m	M5	6/9/12/18	0.8/5.0	5~20	232	500
3200	2m	M5	6/9/12/18	1.0/6.3	5~20	232	500
3200	1Am	M4	6/9/12/18	1.6/10	5~20	254	590
5000	2m	M5	6/9/12/18	0.8/5.0	5~20	254	590
5000	3m	M6	6/9/12/17	1/6.3	5~20	321	740
5000	2m	M5	6/9/12/18	1.6/10	5~20	321	740
6300	1Am	M4	6/9/12/18	0.8/5.0	5~20	254	590
6300	4m	M7	6/9/12/18	0.8/5.0	5~20	321	740
6300	2m	M5	6/9/12/18	1.3/8.0	5~20	321	740
8000	3m	M6	6/9/12/18	0.8/5.0	5~20	321	740
10000	1Am	M4	6/9/12/18	1.0/6.3	5~20	321	740
10000	2m	M5	6/9/12/18	0.8/5.0	5~20	321	740
10000	3m	M6	6/9/12/18	0.66/4.0	5~20	321	740
12500	1Am	M4	6/9/12/18	0.8/5.0	5~20	321	740
12500	2m	M5	6/9/12/18	0.6/4.0	5~20	321	740
12500	1Am	M4	6/9/12/18	1.0/6.3	5~20	321	740
12500	3m	M3	6/9/12/19	0.6/4.0	5~20	411	850
16000	2m	M5	6/9/12/18	0.6/4.0	5~20	411	850
20000	1Am	M4	6/9/12/18	0.6/4.0	5~20	411	850

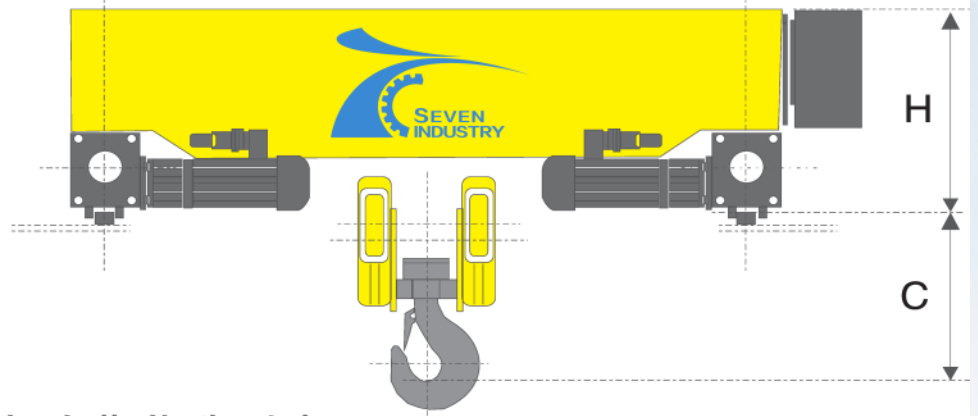

## NWH双梁钢丝绳电动葫芦选型表

Selection table of NWH double girder wire rope hoist

额定载荷 S.W.L (Kg)	工作级别 FEM	工作级别 ISO	起升高度 Lifting height (m)	起升速度 Lifting speed (m/min)	运行速度 Travelling speed (m/min)	H 尺寸 Size H (mm)	C 尺寸 Size C (mm)
2000	3M	M6	6/9/12/18	0.8/5.0	5~20	463	350
3200	2M	M5	6/9/12/18	0.8/5.0	5~20	463	350
5000	2M	M5	6/9/12/18	0.8/5.0	5~20	463	350
6300	1AM	M4	6/9/12/18	0.8/5.0	5~20	463	350
8000	3M	M6	6/9/12/17	0.8/5.0	5~20	580	563
10000	1AM	M4	6/9/12/18	1.0/6.3	5~20	580	563
10000	2M	M5	6/9/12/18	0.8/5.0	5~20	580	563
10000	3M	M6	6/9/12/18	0.66/4.0	5~20	580	563
12500	1AM	M4	6/9/12/18	0.8/5.0	5~20	580	563
12500	1AM	M4	6/9/12/18	1.0/6.3	5~20	679	700
12500	2M	M5	6/9/12/18	0.6/4.0	5~20	679	700
16000	2M	M5	6/9/12/18	0.66/4.0	5~20	679	700
20000	1AM	M4	6/9/12/18	0.66/4.0	5~20	679	700
20000	2M	M5	6/9/12/18	0.53/3.4	5~20	679	700
20000	3M	M6	6/9/12/18	1.0/4.2	5~20	864	1000
25000	1AM	M4	6/9/12/18	0.53/3.4	5~20	864	1000
25000	3M	M6	6/9/12/18	0.8/3.3	5~20	864	1000
25000	2M	M5	6/9/12/18	1.0/4.2	5~20	864	1000
32000	2M	M5	6/9/12/18	0.8/3.3	5~20	864	1000
32000	2M	M5	6/9/12/18	0~4.9	5~20	1023	950
40000	1AM	M4	6/9/12/18	0~4.9	5~20	1023	950
50000	2M	M5	6/9/12/18	0~3.2	5~20	1023	950
50000	1AM	M4	6/9/12/18	0~4.1	5~20	1023	950
63000	1AM	M4	6/9/12/18	0~3.2	5~20	1023	950
63000	2M	M5	6/9/12/18	0~2.4	5~20	1023	1110
80000	1AM	M4	6/9/12/18	0~2.4	5~20	1023	1110

更多参数及非标产品请与速巍公司联系  
Contact SEVENCRAINE for more parameters and non-standard products